



---

MODULAR CRESCENT CUBER  
MACHINE A GLACONS CROISSANT MODULAIRE  
MODULARER CRESCENTEISBEREITER  
MODULAIRE MACHINE VOOR HALVEMAANVORMIGE IJSBLOKJES  
MÁQUINA MODULAR DE CUBITOS EN FORMA DE MEDIA LUNA  
FABBRICATORE DI GHIACCIO IN CUBETTI MODULARE A FORMA DI MEZZALUNA

**INSTRUCTION MANUAL  
NOTICE D'UTILISATION  
BEDIENUNGSANLEITUNG  
GEBRUIKSAANWIJZING  
MANUAL DE INSTRUCCIONES  
MANUALE D'ISTRUZIONI**

**KMD-201AA  
KMD-201AWA**

## IMPORTANT

1. This booklet is an integral and essential part of the product and should be kept and preserved by the user. Please read carefully the guidelines and warnings contained herein as they are intended to provide the installer/user with essential information for the proper installation and the continued safe use and maintenance of the product. Please preserve this booklet for any further consultation that may be necessary.
2. This is a commercial icemaker, and should be destined only to be used for the purpose for which it has been expressly designed. Any other use should be considered improper and therefore dangerous. The manufacturer will not be held liable or responsible for any damage caused by improper, incorrect and unreasonable use.

## I. INSTALLATION INSTRUCTIONS

### WARNING

The installation must be carried out by qualified personnel, in accordance with current regulations, according to the manufacturer's instructions.

### 1. UNPACKING

#### WARNING

Children should not be allowed in reach of the packaging elements (plastic bags and expanded polystyrene) as they are potential sources of danger.

#### CAUTION

Remove shipping carton, tape(s) and packing. If packing material is left in the icemaker, it will not work properly.

## 2. LOCATION

### IMPORTANT

1. This icemaker is not intended for outdoor use. Normal operating ambient temperature should be within 7°C to 40°C. Normal operating water temperature should be within 7°C to 35°C. Operation of the icemaker, for extended periods, outside of these normal temperature ranges may affect production capacity.
2. The icemaker should not be located next to ovens, grills or other high heat producing equipment.
3. The location should provide a firm and level foundation for the equipment.
4. Allow 15 cm clearance at rear, left side and top and 30 cm clearance at right side for proper air circulation and ease of maintenance and/or service should they be required.
5. This appliance is not suitable for installation in an area where a water jet could be used and where dripping is not allowed.
6. Do not place anything on top of the icemaker or in front of the Louver.
7. This icemaker will not work at subfreezing temperatures. To prevent damage to the water supply line, drain the icemaker when air temperature is below zero (see "II. 2. PREPARING THE ICEMAKER FOR LONG STORAGE").

## 3. INSTALLATION

- \* Incorrect installation can cause harm to people, animals or things, for which the manufacturer cannot be held responsible.
- \* Place the icemaker in the selected permanent site.
- \* The appliance must be positioned so that the plug is accessible.

## 4. BIN CONTROL INSTALLATION

- 1) Remove the Front Panel, then remove the Front Insulation.
- 2) Loosen the two Thumbscrews securing the Pump Motor Bracket. See Fig. 2.

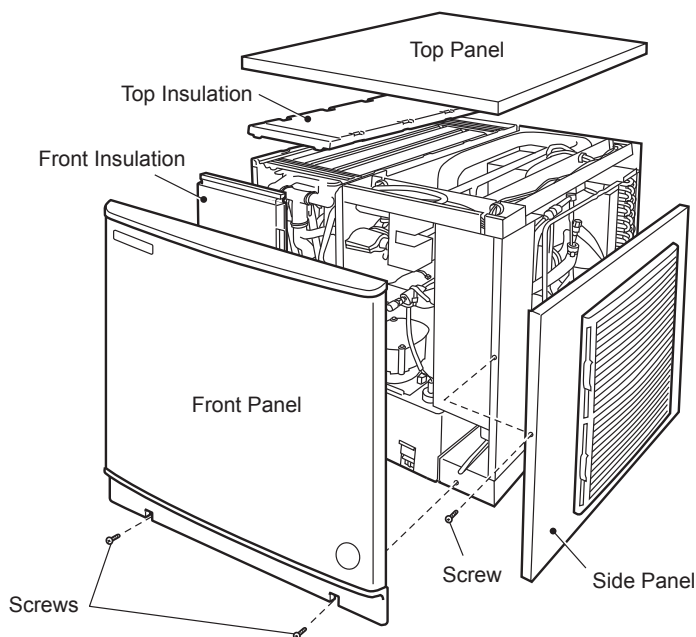

Fig. 1

- 1) After removing the packaging, make sure that the icemaker is in good condition. If in doubt, please do not use the equipment but apply to professionally qualified personnel.
- 2) Remove shipping tape holding the components.
- 3) Remove the protective plastic film from the exterior. If the icemaker is exposed to the sun or to heat, remove the film after the icemaker cools.
- 4) Remove the package of accessories, and check the contents:
 

a) Power Supply Cord	1
b) Mounting Bracket	2
c) Bolt	2

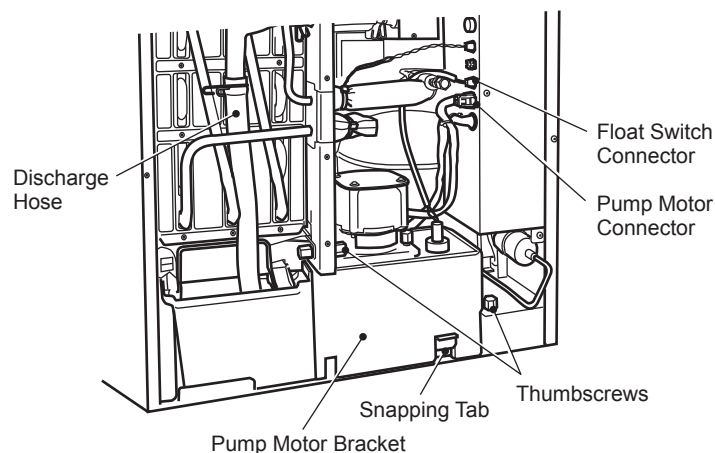
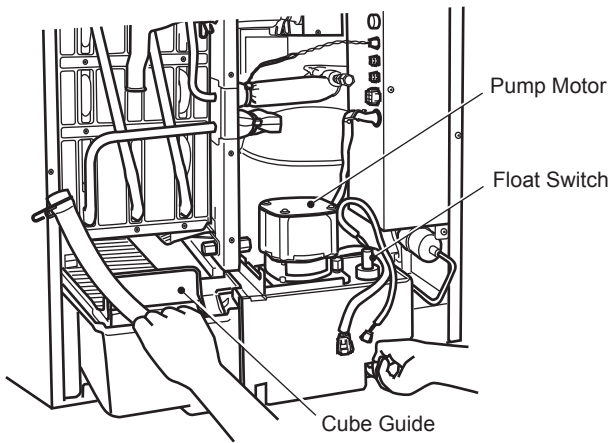

Fig. 2

- 3) Disconnect the Discharge Hose.
- 4) Disconnect the Pump Motor Connector and Float Switch Connector from the side of the Control Box.
- 5) Keep pushing up the Snapping Tab at the right side of the Pump Motor Bracket.
- 6) Pull out the Water Tank, Cube Guide, Pump Motor Bracket, Pump Motor and Float Switch together. See Fig. 3.

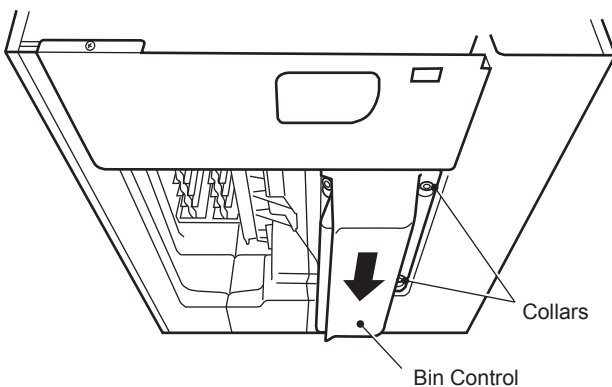

**Fig. 3**

- 7) Pass the Bin Control Connector through the hole from the bottom to the top of the unit.
- 8) While pulling up the Bin Control Lead, hook the Bin Control on the right side interior wall. Then push the Bin Control up against the bottom of the unit, and slide to the back until it snaps in place. Make sure the slotted holes at the right side of the Bin Control are securely placed on the Collars at the bottom of the unit. See Fig. 4.

**CAUTION**

Make sure the Bin Control is securely in place. Otherwise, ice may get between gaps and damage the Bin Control.



**Fig. 4**

- 9) Connect the Bin Control Connector to the side of the Control Box.
- 10) Replace the Water Tank, Cube Guide, Pump Motor Bracket, Pump Motor and Float Switch in their correct positions until they snap in place.
- 11) Secure the Pump Motor Bracket with the two Thumbscrews.
- 12) Reconnect the Pump Motor Connector and Float Switch Connector.
- 13) Replace the Front Insulation and Front Panel in their correct positions.

## 5. ELECTRICAL CONNECTIONS

**WARNING**

**THIS APPLIANCE MUST BE EARTHED**

This icemaker requires an earth that meets the national and local electrical code requirements. To prevent possible severe electrical shock to individuals or extensive damage to equipment, install a proper earth wire to the icemaker. Remove the plug from the mains socket before any maintenance, repairs or cleaning is undertaken.

- \* This icemaker must have a separate power supply or receptacle of 220 - 240V.
- \* The main control box fuse is rated at 5A and should only be replaced by a qualified service engineer.
- \* Usually an electrical permit and services of a licensed electrician are required.
- \* If the supply cord and the plug should need to be replaced, it should only be done by a qualified service engineer.

### For the U.K. and the Republic of Ireland only

- \* The wires in the mains lead are coloured in accordance with the following code:

Green & Yellow = Earth  
 Blue = Neutral  
 Brown = Live

As the colours of the wire in the mains lead of this appliance may not correspond with the coloured markings identifying the terminals in your plug, proceed as follows:

The wire which is coloured Green-and-Yellow must be connected to the terminal in the plug which is marked with the letter E or by the symbol  $\perp$  or coloured Green or Green-and-Yellow. The wire which is coloured Blue must be connected to the terminal which is marked with the letter N or coloured Black. The wire which is coloured Brown must be connected to the terminal which is marked with the letter L or coloured Red.

- \* Should the socket outlets in the installation site not be suitable for the plug supplied with your product, the plug must be removed (cut off if it is moulded on plug) and an appropriate plug fitted.

If the non-rewirable plug has been cut from the power supply cord, it must be disposed of. There should be no attempt to reuse it. Inserting such a plug into a socket elsewhere presents a serious risk of electrical shock.

- \* The non-rewirable plug must never be used without a fuse cover being fitted.

The correct replacement for the detachable fuse cover is identifiable from the manufacturer's reference number stamped on the plug.

Supply of replacement fuse covers can be obtained from Hoshizaki Parts/Service Centres.

Fuses should be rated at 10A and approved to BS 1362.

## 6. WATER SUPPLY AND DRAIN CONNECTIONS

(For the U.K. only, the connections must be in accordance with current requirements of the Model Water Byelaws 1986 SI No. 1147)

- \* Only potable water should be used for this icemaker.
- \* To avoid performance reduction or malfunction caused by scaling, the water supply should have a hardness of not more than 50 mg/L and a silica content of not more than 30 mg/L. Otherwise, installation of a proper water treatment device will be required.
- \* Water supply pressure should be minimum 0.7 bar and maximum 8 bar. If the pressure exceeds 8 bar, use a pressure reducing valve. Do NOT throttle back the supply tap.
- \* A plumbing permit and services of a licensed plumber may be required in some areas.
- \* Water should drain into an open trap.
- \* The icemaker drain is gravity flow, so ensure drain pipe has an adequate pitch or fall.

- \* A vented tee connection is required for proper drain flow. See Fig. 5.
- \* The icemaker drain line must be run separately from the storage bin/dispenser unit drain line. See Fig. 5.
- \* There should be no backflow in the water circuit.
- \* Water supply connection is intended to be made by means of a pipe, not a hose set.

Note: Jointing compounds should be approved and suitable for potable water use.

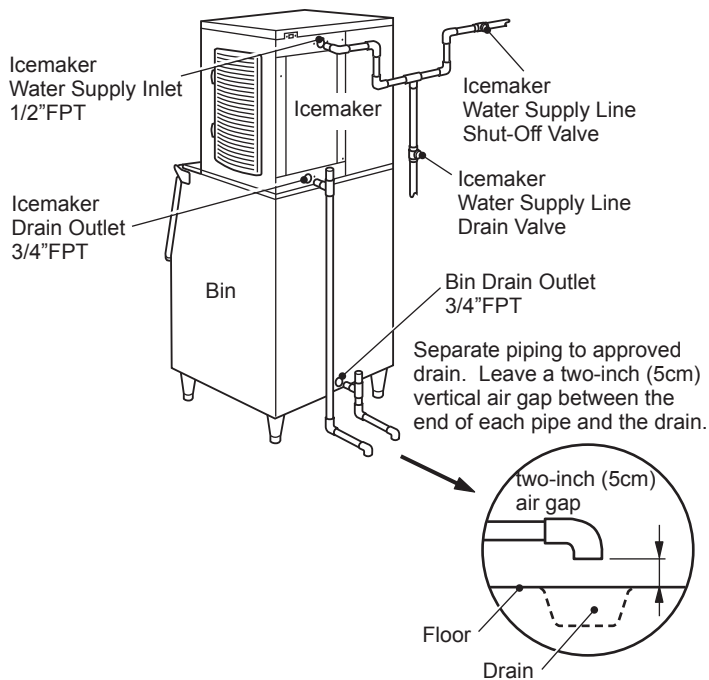

Fig. 5

## II. OPERATING INSTRUCTIONS

### WARNING

1. This icemaker is designed to produce edible ice. To keep the icemaker hygienic:
  - \* Wash your hands before removing ice. Use the Plastic Scoop provided (accessory).
  - \* The Storage Bin is for ice use only. Do not store anything else in the Bin.
  - \* Clean the Storage Bin before use (see "III. 1. CLEANING").
  - \* Keep the Scoop clean. Clean it by using a neutral cleaner and rinse thoroughly.
  - \* Close the Door after removing ice to prevent entrance of dirt, dust or insects into the Storage Bin.
2. The use of any electrical equipment involves the observance of some fundamental rules. In particular:
  - \* Instances of high humidity and moisture increase the risk of electrical short circuits and potential electrical shocks. If in doubt, disconnect the icemaker.
  - \* Do not pull the power cord in order to disconnect the icemaker from the feed network.
  - \* This appliance is not suitable for unsupervised use by young children or aged or infirm persons.
3. All parts are factory-adjusted. Improper adjustments may result in failure.
4. If the unit is turned off, wait for at least 3 minutes before restarting the icemaker to prevent damage to the Compressor.

## 1. OPERATION

The installer will normally commission the icemaker to start the automatic icemaking process. To ensure continuous operation, make sure that:

- \* The water supply tap is on,
- \* The icemaker is plugged into the power supply, and
- \* The Control Switch is in the "ICE" position.

## 2. PREPARING THE ICEMAKER FOR LONG STORAGE

- 1) Move the Control Switch to the "OFF" position.
- 2) Unplug the icemaker or disconnect the power supply.
- 3) Close the water supply tap, and remove the Inlet Hose.
- 4) Remove all ice from the Storage Bin/Dispenser, and clean the Bin/Dispenser.
- 5) Ask for draining of the icemaker by professional qualified personnel.

## III. MAINTENANCE

### 1. CLEANING

#### WARNING

1. Before carrying out any cleaning or maintenance operations, unplug the icemaker from the electrical supply network.
2. Ask a trained service person to clean and sanitise the icemaker water system at least twice a year and to check and clean the Condenser at least once a year.
3. This appliance must not be cleaned by use of a water jet.
4. Do not use any alcohol for cleaning/sanitisation of the icemaker. It may cause cracks on the plastic parts.

#### [1] Machine and Bin Exterior

Wipe the exterior at least once per week with a clean, soft cloth. Use a damp cloth containing a neutral cleaner to wipe off grease or dirt.

#### [2] Scoop

- 1) Either mix 3 litres of water with 11 ml of 5.25% sodium hypochlorite solution in a suitable container, or the recommended Hoshizaki sanitiser as directed.
- 2) Soak the Scoop in the solution for more than 3 minutes. Rinse thoroughly, and shake to remove surplus liquid.

Note: Using a cloth to dry may re-contaminate.

#### [3] Storage Bin Interior Cleaning/Sanitisation (Weekly)

- 1) Open the Storage Bin Door, and remove all ice.
  - Note: Hoshizaki recommends various types of Storage Bin for the icemaker which vary in size and design. The following instructions are therefore for general guidance only.
- 2) Wash the Bin liner and Door inner surface with a neutral non-abrasive cleaner. Rinse thoroughly with a clean cloth and fresh water.
- 3) Either mix 5 litres of water with 18 ml of 5.25% sodium hypochlorite solution in a suitable container or the recommended Hoshizaki sanitiser as directed.
- 4) Soak a clean sponge or cloth with the solution, and wipe the Bin liner and Door inner surface.

# ENGLISH

5) Rinse thoroughly with fresh water and a clean cloth to wipe off the solution. Close the Bin Door.

Note: Some solutions may cause damage to the Bin liner surfaces or corrosion on the metal parts. **Always** rinse the sanitiser unless directed otherwise by Hoshizaki guidelines.

## [4] Air Filter

A plastic mesh Air Filter removes dirt or dust from the air, and keeps the Condenser from getting clogged. As the Filter gets clogged, the icemaker's performance will be reduced.

1) Remove the Air Filter.

Note: Do not put your hand inside the machine compartment.

2) Clean the Air Filter by using a vacuum cleaner. When severely clogged, use warm water and a neutral cleaner to wash the Air Filter.

3) Rinse and dry the Air Filter thoroughly, and place it in position.

## [5] Icemaking Water System

To keep the icemaker hygienic, periodic cleaning of the icemaking water system is recommended. Always ask a trained service person to clean the water system.

Note: 1. The Washing Switch on the Control Box is intended for use by service personnel only.

2. During normal icemaking operation, keep the Washing Switch in the "ICE" position.

## 2. BEFORE CALLING A SERVICE AGENT

If the icemaker does not work properly or does not work at all, before calling for service, check that:

- \* The power is supplied to the unit.
- \* The Control Switch is in the "ICE" position.
- \* The water is turned on.
- \* The Air Filter is clean.

For further assistance or advice, contact your local Hoshizaki service agent.

## 3. WARRANTY

Hoshizaki warrants to the original owner/user that all Hoshizaki branded products shall be free of defects in material and/or workmanship for the duration of the "warranty period". The warranty shall be effective for two years from the date of installation. Hoshizaki's liability under the terms of the warranty are limited and shall exclude routine servicing, cleaning, essential maintenance and/or repairs occasioned by misuse and installations not in accordance with Hoshizaki guidelines.

Warranty repairs should be completed by an approved Hoshizaki dealer or service agency using genuine Hoshizaki components.

To obtain full details of your warranty and approved service agency, please contact your dealer/supplier, or the nearest Hoshizaki Service office:

### Europe

U.K./Ireland - Hoshizaki UK  
TEL : +44 (0)845 456 0585  
FAX: +44 (0)1462 499080

Holland - Hoshizaki Europe  
TEL : +31 (0)20 6918499  
FAX: +31 (0)20 6918768

Belgium/Luxemburg - Hoshizaki Belgium  
TEL : +32 (0)2 7123030  
FAX: +32 (0)2 7123031

Germany/Switzerland/Austria - Hoshizaki Deutschland  
TEL : +49 (0)2154 92810  
FAX: +49 (0)2154 928128

France - Hoshizaki France  
TEL : +33 (0)1 48639380  
FAX: +33 (0)1 48639388

Spain/Portugal - Hoshizaki Iberia  
TEL : +34 (0)93 4780952  
FAX: +34 (0)93 4780900

Other countries - Hoshizaki Europe  
TEL : +31 (0)20 6918499 or +44 (0)845 456 0585  
FAX: +31 (0)20 6918768 or +44 (0)1462 499080

### Other than Europe

Hoshizaki Singapore  
TEL : +65 6225 2612  
FAX: +65 6225 3219

Hoshizaki Lancer Pacific  
TEL : +61 8 8268 1388  
FAX: +61 8 8268 1978

Hoshizaki Suzhou  
TEL : +86 512 62807850  
FAX: +86 512 62807860

**This product includes a hermetically sealed refrigeration system that contains fluorinated greenhouse gases covered by the Kyoto Protocol:**

**KMD-201AA R404A / GWP 3260 / 0.52kg**  
**KMD-201AWA R404A / GWP 3260 / 0.40kg**

**This product is insulated with foam blown with fluorinated greenhouse gases.**

## EC DECLARATION OF CONFORMITY

Manufacturer: Hoshizaki (Suzhou) Co., Ltd.

Address: No. 15 Qingqiu Street, Suzhou Industrial Park,  
Suzhou 215126 China

We hereby declare that the machine(s) listed below and manufactured by us meet the essential health and safety requirements demanded by the following EC regulations:

EC Regulations: EMC Directive (2004/108/EC)  
Low Voltage Directive (2006/95/EC)

Harmonised European Standards applied: EN 55014-1 (EMC)  
EN 55014-2 (EMC)  
EN 61000-3-2 (EMC)  
EN 61000-3-3 (EMC)  
EN 61000-4-2 (EMC)  
EN 61000-4-3 (EMC)  
EN 61000-4-4 (EMC)  
EN 61000-4-5 (EMC)  
EN 61000-4-6 (EMC)  
EN 61000-4-11 (EMC)  
EN 60335-1 (LVD)  
EN 60335-2-24 (LVD)  
EN 50366 (EMF)

CE Marking first affixed: 2009

Product Description: Hoshizaki Ice Maker

Model(s): KMD-201AA, KMD-201AWA

Name: Teruaki Yoshimura

Position: Vice General Manager

This declaration will no longer be valid if any alterations are made to the machine(s) without our approval.